

INTELLIGENT TEMPERATURE AND AIR RELATIVE HUMIDITY TRANSDUCERS

with the RS485 or RS232 serial output



Computerized design ensures maximum long term stability, temperature compensation of the humidity sensor and fail indication. Measured quantities are converted to digital serial output with the RS485 or RS232 link parameters. Communication protocol is Advantech standard ADAM compatible. Measured values can be in Engineering units or floating decimal point format (IEEE754). It is possible to read the transducer configuration, its type, firmware version, modify the communication parameters including activation of CRC and transducer calibration. Sensor breakage or short circuit is indicated. RS485 transducers have the address space available at the range of 0-255.

State-of-the-art capacitive polymer RH sensor excels in mechanical stress, temperature shock, dew resistance as well as in large linearity range and low hysteresis. RH sensor is designed for measurement of non-aggressive air.

TECHNICAL PARAMETERS

Temperature sensor:	RTD Ni1000-6180ppm/°C
Measuring temperature range:	-30 to +80 °C (models NH485-150, NH485-700: -30 to +105 °C at the end of the tube with sensors see Working range graph)
Accuracy:	±0.4 °C
Measuring RH range:	0 to 100%
Accuracy:	±2.5% RH from 5 to 95% at 23 °C
Range of temperature compensation of the RH sensor:	-30 to +105 °C
Power:	9 to 30V DC, consumption approximately 8mA
Protection of the case with electronics:	IP65
Filtering ability of sintered bronze cover:	0.025mm
Communication protocol:	compatible with the Advantech standard ADAM
Communication speed:	adjustable at range 1200, 2400, 4800, 9600, 19200 Bd

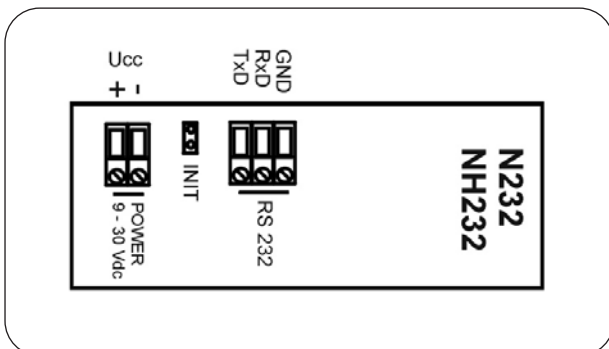

Figure: Interconnection terminals

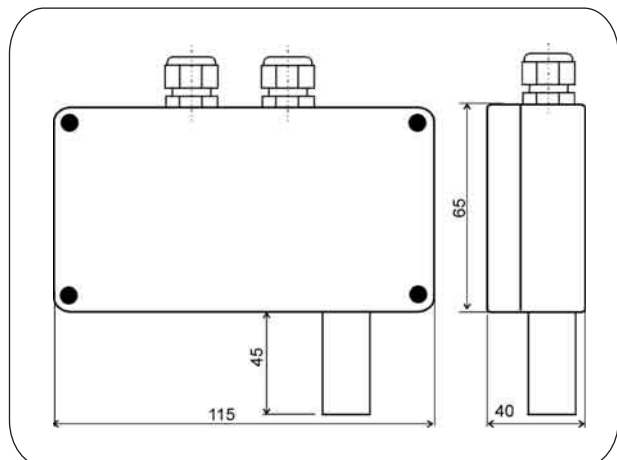

Figure: Photo and mechanical dimensions of N485, N232

INTELLIGENT TEMPERATURE AND AIR RELATIVE HUMIDITY TRANSDUCERS

with the RS485 or RS232 serial output

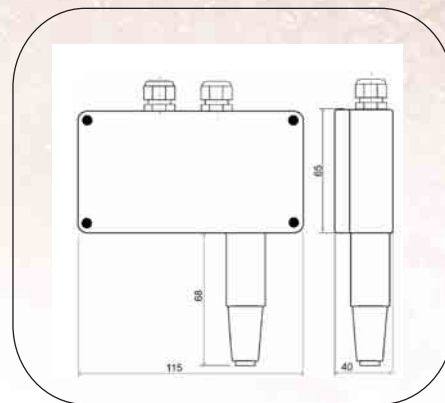

Photo and mechanical dimensions of NH485, NH232

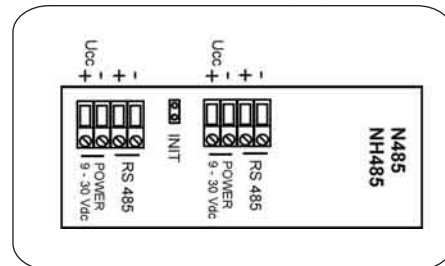
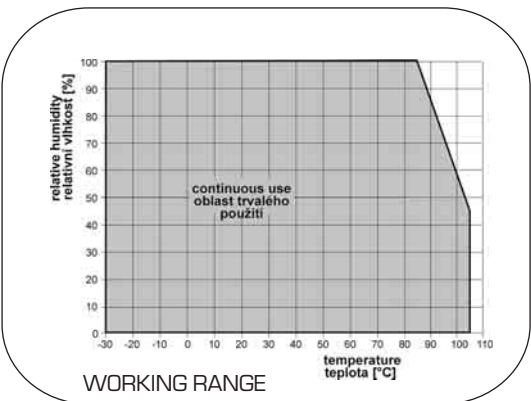

Figure: Interconnection terminals

Transmitters are available at the following types:

TYPE	MEASURED VALUE	TEMPERATURE OPERAT. RANGE	GALVANIC ISOLATION OF COMMUNICATION CIRCUITRY FROM POWER CIRCUITRY	LENGTH	NOTE
TRANSMITTERS WITH RS232 SERIAL OUTPUT					
N232	T	-30 to +80 °C	no	68mm	outdoor, indoor
NH232	T+RH	-30 to +80 °C	no	68mm	outdoor, indoor
TRANSMITTERS WITH RS485 SERIAL OUTPUT					
N485	T	-30 to +80 °C	yes	68mm	outdoor, indoor
NH485	T+RH	-30 to +80 °C	yes	68mm	outdoor, indoor
NH485-150	T+RH	-30 to +105 °C*	yes	150mm	duct mount
NH485-700	T+RH	-30 to +105 °C*	yes	700mm	bar type

* +105 °C only at the end of measuring tip with the limitation accordingly to the Working range graph. Near plastic case with electronic and terminals maximum temperature is +80 °C.

INCLUDED ACCESSORY: calibration certificate from the manufacturer, instruction manual with detailed description of communication protocol. Duct mount and bar type transmitters have included a gland for direct fixing to a 29mm diameter hole. Transmitters with the RS232 output have included 2 meters cable for communication with RS232 computer port.

OPTIONAL ACCESSORY:

- F0000** - spare air filter from sintered bronze (filtering ability of 0.025mm)
- PP4** - flat circular flange for duct mount and bar type transmitters installation
- PP90** - right-angled stainless steel flange for duct mount and bar type transmitters
- A1515** - ac/dc adapter 230V-50Hz/12Vdc stabilized for supplying of the transmitter

APPLICATIONS monitoring and humidity control at warehouses, glass houses, manufacturers, air-conditioned rooms, museums, galleries, archives

WARRANTY: two years